

HermetiX™ Fire safe for cryogenic applications

Non-graphite fire safe stem seal



Cryogenic HermetiX™ fire safe valve series

Habonim extended the use of the revolutionary non-graphite-fire-safe HermetiX™ stem seal into the cryogenic industry.

The unique stem seal specially built into Habonim's line of cryogenic valves, is a superior solution for applications like LNG, liquid oxygen, and other flammable cryogenic fluids. It improves the performance of valve stem sealing over time, compared to a porous graphite stem seal, as well as eliminating a possible source of ignition or contamination caused by the presence of graphite particles such as in traditional fire safe stem seals.

Non-graphite stem seal

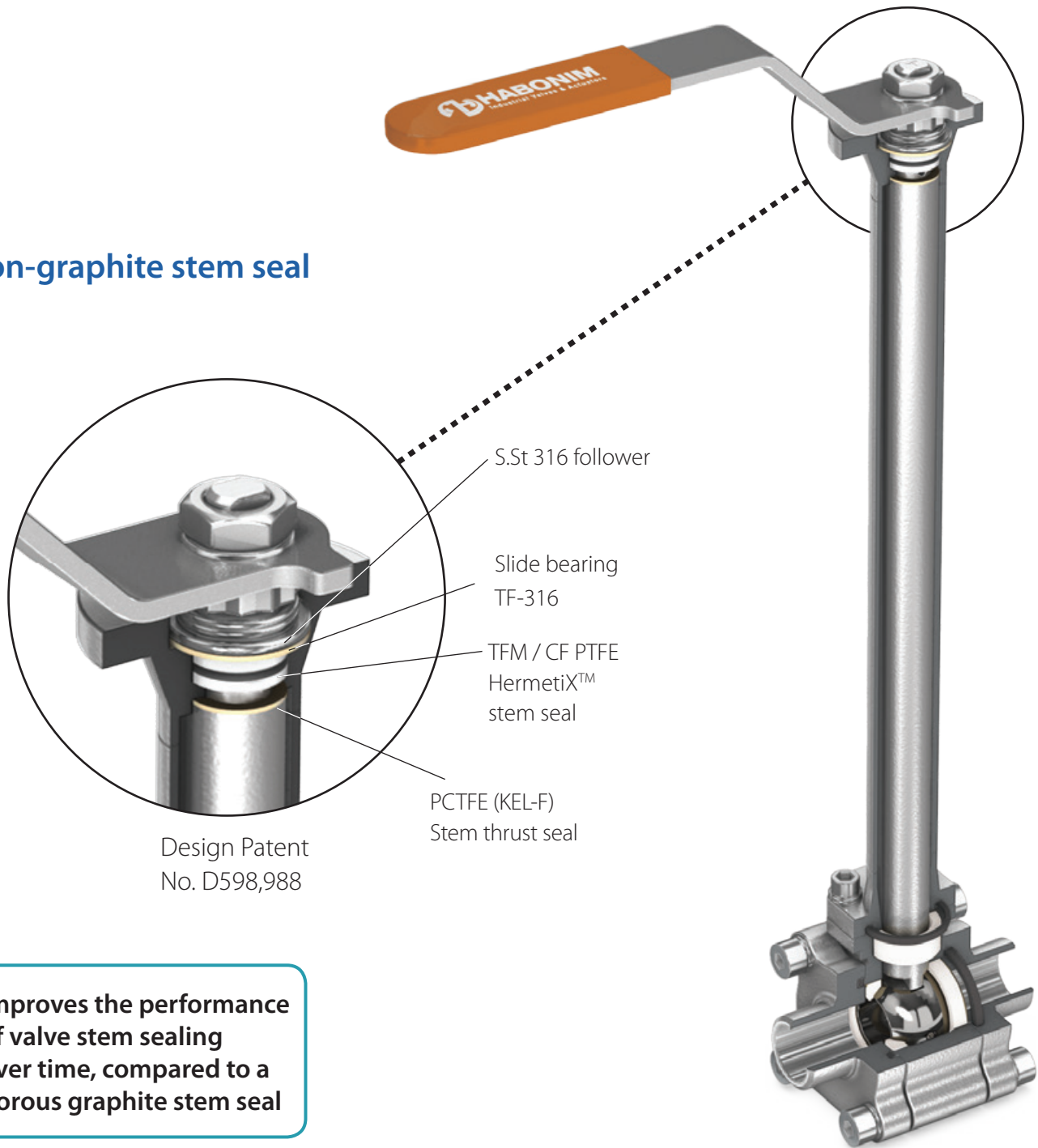

Design Patent
No. D598,988

Improves the performance of valve stem sealing over time, compared to a porous graphite stem seal

HermetiX™ fire safe cryogenic valve series features

- Particle risk in liquid oxygen
- Increases site safety
- Fugitive emission certified to ISO 15848-1
- Fire safe certified to API 607 and ISO 10497
- Minimize shutdowns for maintenance up to 500,000 cycles
- Ensures uninterrupted production
- Habonim design Patent No. D598,988



HermetiX™ superior stem seal

The patented HermetiX™ stem seal is named for its distinctive “X”-shaped design. The flexible “X” shape creates a dynamic sealing arrangement so that in the event of pressure buildup or side load, the HermetiX™ dynamically adjusts to prevent fugitive emissions. This results in a superior stem seal design compared to conventional flat stem seals or porous ring shaped graphite seals, both traditional designs currently available on the market.

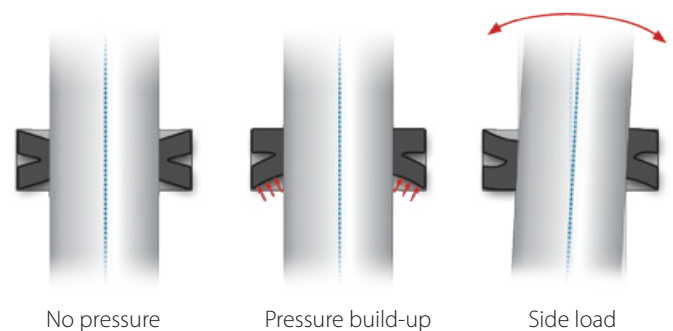

HermetiX™ fire safe stem seal holds up in fire test

During the fire test, pressure pushes the valve stem upwards, causing a metal-to-metal seal between the stem fire lip and the valve body. After cooling down, holding the stem aligned becomes crucial in order to allow valve rotation to the open position and a successful final shell test. Traditional graphite based sealing components function only as a base to hold the stem parts aligned. Habonim’s unique graphite-free stem seal components, allow the stem to stay aligned and operable after cooling, even after the polymer materials have melted.

Certifications and standards of compliance

ISO 15848-1 Industrial valves - Measurement, test and qualification procedures for fugitive emissions. Part 1: Classification system and qualification procedures for type testing of valves

API 607 / ISO 10497 Testing of valves - Specifies fire type testing requirements and a fire type-test method for confirming the pressure containing capability of a valve under pressure during and after the fire test.

ANSI B16.34 Design standard - Valves Flanged, Threaded and Welding End

BS 6364 Specification for valves for cryogenic service

BS ISO 21011 & BS EN 1626 Cryogenic vessels - Valves for cryogenic service

CGA G-4.1 (1996) - Cleaning equipment for Oxygen service

Linde standard LS 141-74 part 1&2 Cleaning of surfaces in air separation plants and components

Cryogenic HermetiX™ fire safe valve series

Three-piece FC47W series

Flanged, full port #150/#300 FC73W/F74W series

Three-piece #600 FC26W series

Flanged, full port, PN16/PN40 FC77W /F78W series

Three-piece High-pressure #2500 FC28W series

Multi-port #600 C61W/C62W series

Flanged, #150/#300 FC31W/F32W series



Standard cryogenic valve



Cryogenic HermetiX™ fire safe

